

e+po

Product Data Sheet

Motor Pressurization System

IECEX & ATEX Certified Purging and Pressurization System for Large Electrical Machines.

D758 / D771 MOTOR SYSTEMS

Hazardous Area classification
IECEX Zone 1 (21), Group IIC T6
ATEX Category 2 G D, Zone 1 (21), Group IIC T6
D771 Provides Intrinsically Safe Outputs

IECEX
& ATEX
Certified!



**D758 Motor System
Control Unit**

**Relief Valve
(RLV)**

OPERATION

The Motor Purging & Pressurization control system has been specifically designed for use on large electrical machines to be located in a hazardous location.

The system has a High Purge rate to remove the gasses that may be present within the machine prior to start-up. The purge flow rate and duration is normally established by the manufacturer & Notified Body during the machine testing. On completion of High Purge the system switches to Closed Loop Automatic Leakage Compensation. This automatically compensates for pressure variations in the machine which are typically caused during start-up or due to temperature fluctuations. The machine will then continuously operate at a constant pressure offering the Manufacturer considerable savings in time on the test bed & the Plant Operator ease of Commissioning & Operation.

COMPONENTS

The system has two components. The Control Unit controls air flow and monitors flow & pressure. It also contains the pneumatic logic controlling the purge timer circuits & volt free / dry system status contacts. The Relief Valve (RLV) provides over-pressure protection for the machine enclosure, the purge flow measurement on the outlet and provides the outlet path for the purge airflow via an integral spark arrestor.

FEATURES

- + Entirely pneumatic operation using the same compressed air supply for Purging, Pressurization and Control Logic.
- + Air regulation & filtration provided.
- + IECEX & ATEX certified Ex [px] to IEC / EN 60079-0 & IEC / EN 60079-2, IECEX & ATEX certified Ex pD to IEC / EN 61241-0 & IEC / EN 61241-4
- + User selectable purge flow rates with 5 pre - set ranges from 2,000 NI/min to 6,000 NI/min.
- + User selectable purge time increments up to a maximum of 45-minutes.
- + One design of system may be fitted to a variety of machine frame sizes due to the user selectable options.
- + Closed Loop Automatic Pressurization System (CLAPS) for fully automatic control of the pressure in the machine during start-up and normal operation.
- + Simple installation on to the side of the machine with minimal pipework required between the Control Unit & RLV.
- + Clear visual status indication.
- + Remote alarm contacts.
- + Patented magnetic Relief Valve.

www.expoworldwide.com



ISO 9001

Technical Specification

Motor Pressurization system

D758 / D771 Motor System

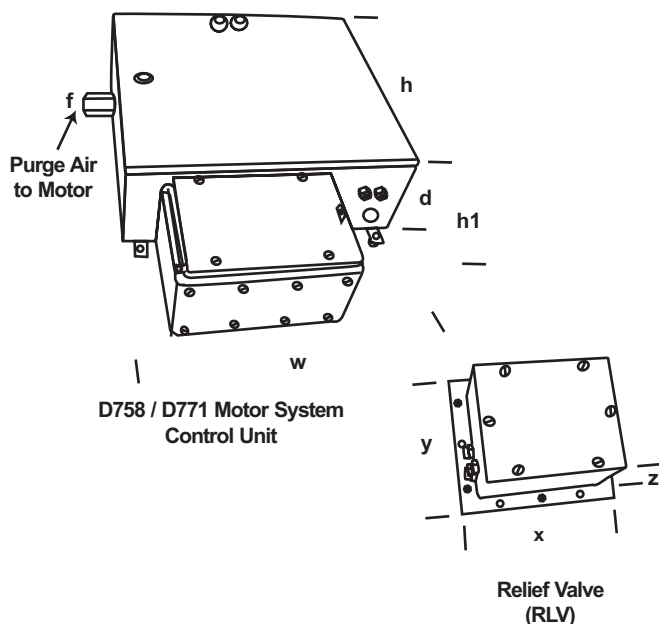

Dimensions/Spec.		D758 / D771	
Width	w	18.9"	480mm
Height	h	16.7"	425mm
Height + SJB	h1	24.5"	622mm
Depth	d	7.0"	177mm
Fitting	f	1" NPT	1" NPT
RLV Width	x	13.0"	330mm
RLV Height	y	11.0"	280mm
RLV Depth	z	6.0"	153mm

OPTIONS

- Intrinsically safe alarm & interlock volt free / dry contacts. The Ex e junction box & terminals are substituted for Ex i equivalents.
Order Code: D771MOTORSYSTEM
- Air Inlet 1" Ball Valve for local isolation of the system. To suit the D758 & D771 systems.
Order Code: D758BALLVV
- Air Inlet "Ex" approved 1" Solenoid Valve for remote isolation of the system. To suit the D758 & D771 systems.
Order Code: D758SOLVV
- Extended timer option for additional 60 minute timer.
Order Code: KGM-PR00-008
- External manual override switch, supplied loose.
Order Code: /MO (BOX)

CONTROL UNIT SPECIFICATION

Model Number

5XLC/ss/OV/PA/PC/D758

Type of Operation

Automatic Purging & Leakage Compensation

Action on Pressure Failure

Alarm and Trip / Disconnect of machine interlocks
(Alarm Only operation user adjustable)

Certification

IEC Zone1 (21) Ex [px] II T6

ATEX II 2 (2) G D Ex [px] II T6

Purge Time Increments: 10, 15 and 20 minutes, giving a maximum available period of 45-minutes (60min timer optional)

Leakage Compensation (LC) Capacity

Up to 1500 NI/min @ 5 barg inlet pressure

Automatic LC Over Capacity

+40% of the normal enclosure leakage flow rate

Compressed Air Supply

Clean Dry Oil free Air or Inert Gas.

Min supply pressure 5 barg, Max 16 barg

Supply inlet filter 40µ and regulator fitted

Process Connections

Purge supply: 1" NPT female, recommended supply pipe: 1" I.D min.

Purge outlet to machine: 1" NPT female

Reference points & signals: 1/8" NPT female

Motor Interlock Contacts

2 pole normally open (DPNO), 4A 250V AC15 ATEX Ex d II T6 or IS

Alarm Contact, Pressure Correct / Not Correct

1 pole changeover (SPCO), 4A 250V AC15 ATEX Ex d II T6 or IS

Intermediate Pressure / Pre-alarm Contact

1 pole changeover (SPCO), 4A 250V AC15 ATEX Ex d II T6 or IS

Signal Junction Box (SJB)

316L Stainless steel, ATEX II 2 G D [Ex e] II T5 certified, c/w terminals, front access cover & lower removable gland plate

Enclosure & Mounting

Housing & external process connections 316L stainless steel

Wall mounting lugs & spaces provided for fitting to machine

Weight

D758 Motor System 27 kg 59.4 lb

Temperature Range

-20°C, -4°F to 55°C, 131°F

System Sensors

Minimum pressure sensor range: 0.5 to 5 mbarg (Default 1.5 mbarg)

Intermediate sensor/pre-alarm range: 2 to 10 mbarg (Default 5 mbarg)

Purging flow sensor set at 8.5 mbarg

Normal working pressure in machine: 10 mbarg maintained by the

Closed Loop Automatic Pressure System (CLAPS) sensor

RELIEF VALVE SPECIFICATION

Model Number

RLV104/ss/FS/D758

Purge Flow Ranges: 2000, 3000, 4000, 5000 & 6000 NI/min

User adjustable by fitting the appropriate orifice plate

Enclosure & Mounting

Housing & external process connections 316L stainless steel

Rectangular flat flange mounting to machine

Weight

Relief Valve 7kg 15.4lb

Relief Valve

Lift-off range 20 to 50 mbarg (Default 30 mbarg)

Expo Technologies Ltd

Summer Road, Thames Ditton,
Surrey, KT7 0RH, UK

T +44 (0) 20 8398 8011

F +44 (0) 20 8398 8014

E sales@expoworldwide.com

Expo Technologies Inc

9140 Ravenna Road, Unit 3,
Twinsburg, 44087, OH, USA

T 888-NFPA-496 (Toll Free)

F +1 440 247 5409

E sales.na@expoworldwide.com

www.expoworldwide.com

Expo Technologies reserve the right to amend data given here without prior notice.
©2003 Expo Technologies. Mini-Z-Purge™ is a trademark of Expo Technologies.